

BREAKFAST

ISTRUZIONI DI MONTAGGIO ASSEMBLY INSTRUCTIONS

MODELLO
MODEL:

1-901-060 Breakfast

CONTENUTO DELLA CONFEZIONE INCLUDED IN THE PACKAGING

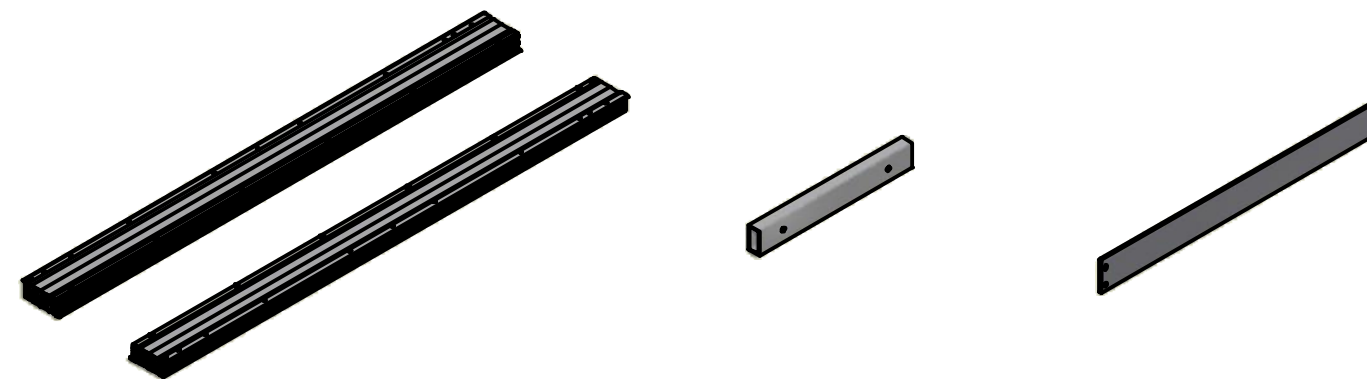

GUIDE
SLIDES

TRAVERSO
CONNECTION BAR

PIATTO
PLATE

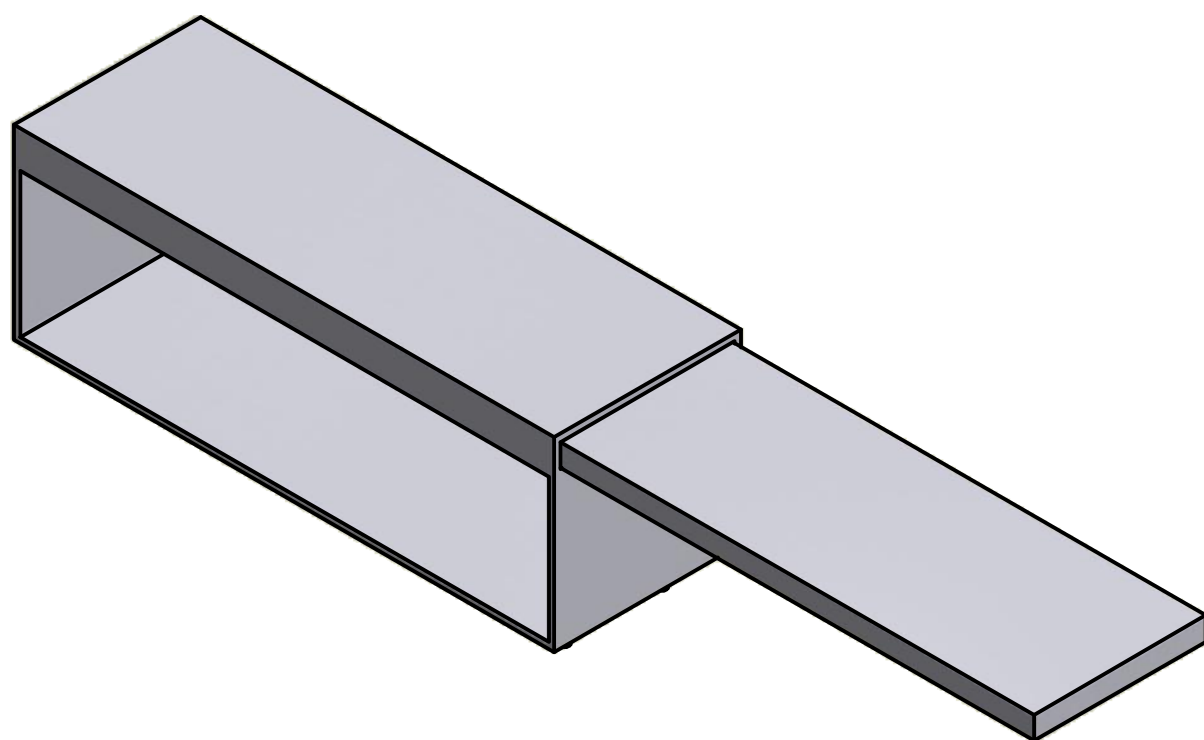

ACCESSORIES



A. Chiave esa. n.5 - n.5 Allen key



B. Chiave esa. n.4 - n.4 Allen key



C. Bussola M6 12x8 mm - Bush M6 12x8 mm (x24)



D. Giunto in plastica - Plastic joint (x2)

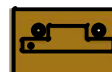

E. Giunto in zamak - Zamak joint (x2)



F. Vite TPS M6x10 - M6x10 tapered screw (x4)



G. Vite TCCE M6x16 - Socked head cap screw M6x16 (x2)



H. Vite TCCE M6x30 - Socked head cap screw M6x30 (x4)



I. Vite TPS M6x65 - M6x65 tapered screw (x28)

DIMENSIONI DI MASSIMA
GENERAL DIMENSIONS

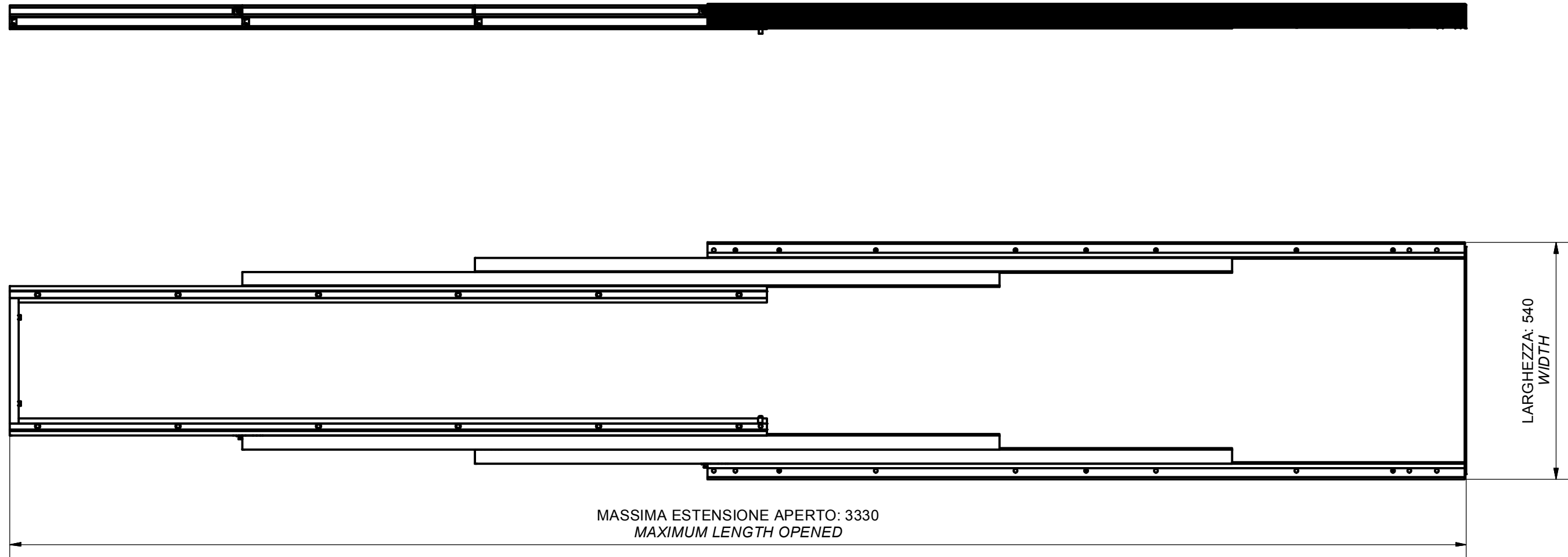

DIMENSIONI GENERALI MOBILE GENERAL CABINET DIMENSIONS

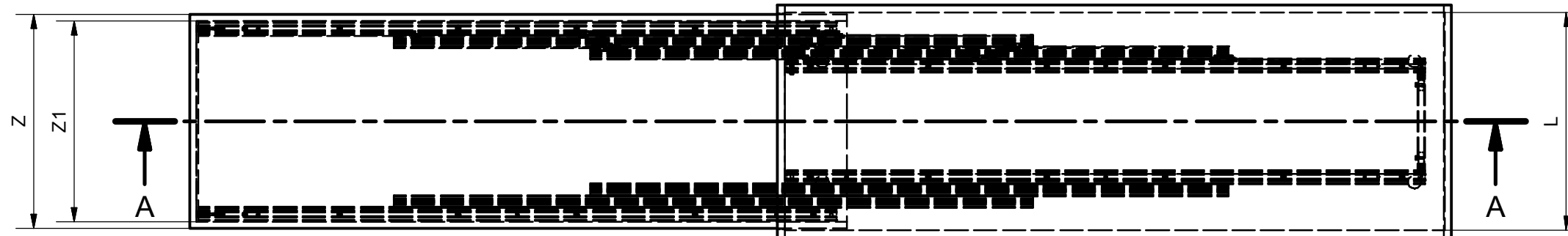
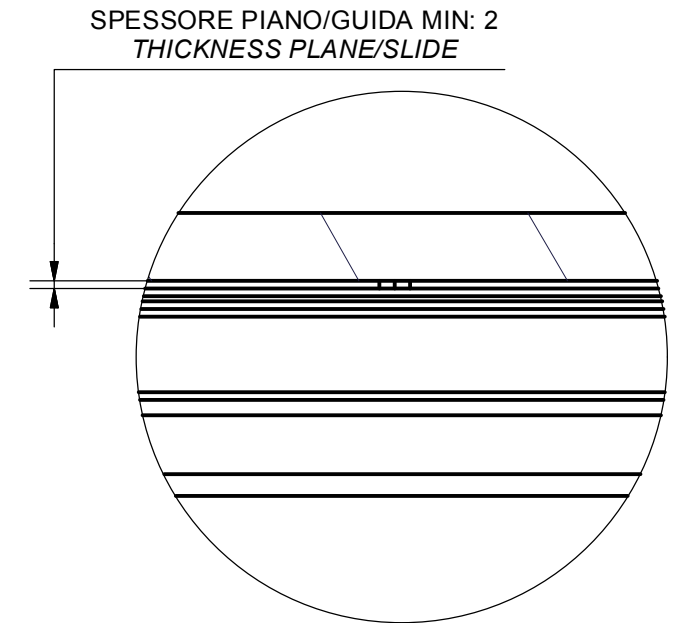
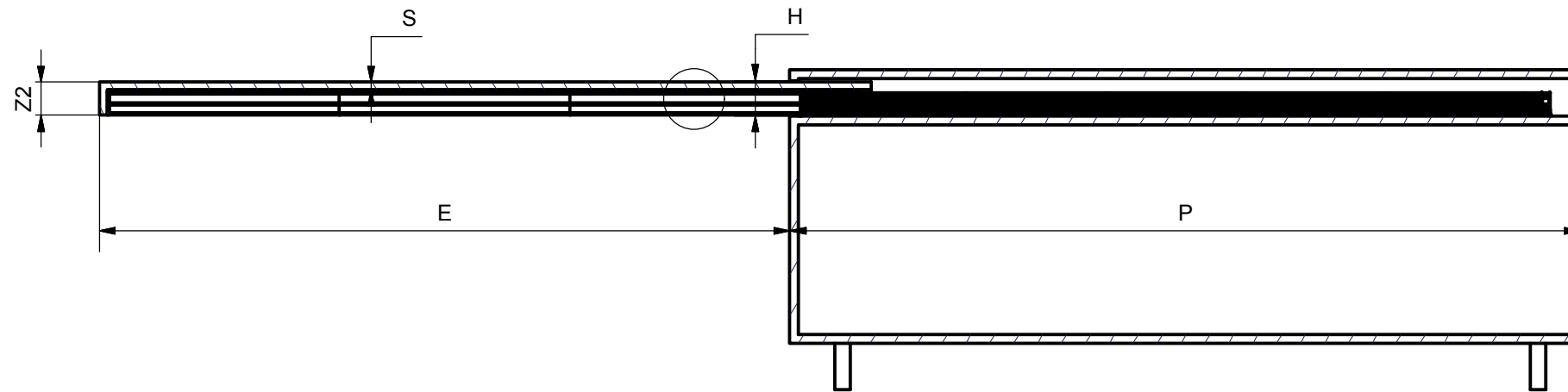

DIMENSIONE - DIMENSION	SIMBOLO - SYMBOL	
LUCE VERTICALE - VERTICAL FREE SPACE	H	MIN: 80 mm
PROFONDITA' INTERNA - INTERNAL FREE SPACE	P	MIN: 1780 mm
LARGHEZZA INTERNA MODULO - CABINET INTERNAL WIDTH	L	MIN: 600 mm
SPESSORE PIANO - PLANE THICKNESS	S	MIN: 18 mm
LARGHEZZA PIANO - PLANE WIDTH	Z	MIN: L-5
LARGHEZZA INTERNA PIANO - PLANE INTERNAL WIDTH	Z1	MIN: 560 mm
ALTEZZA FRONTE - FRONT HEIGHT	Z2	H-5
APERTURA PIANI - OPENING PLANE	E	1600 mm

DIMENSIONI MODULO CABINET DIMENSIONS

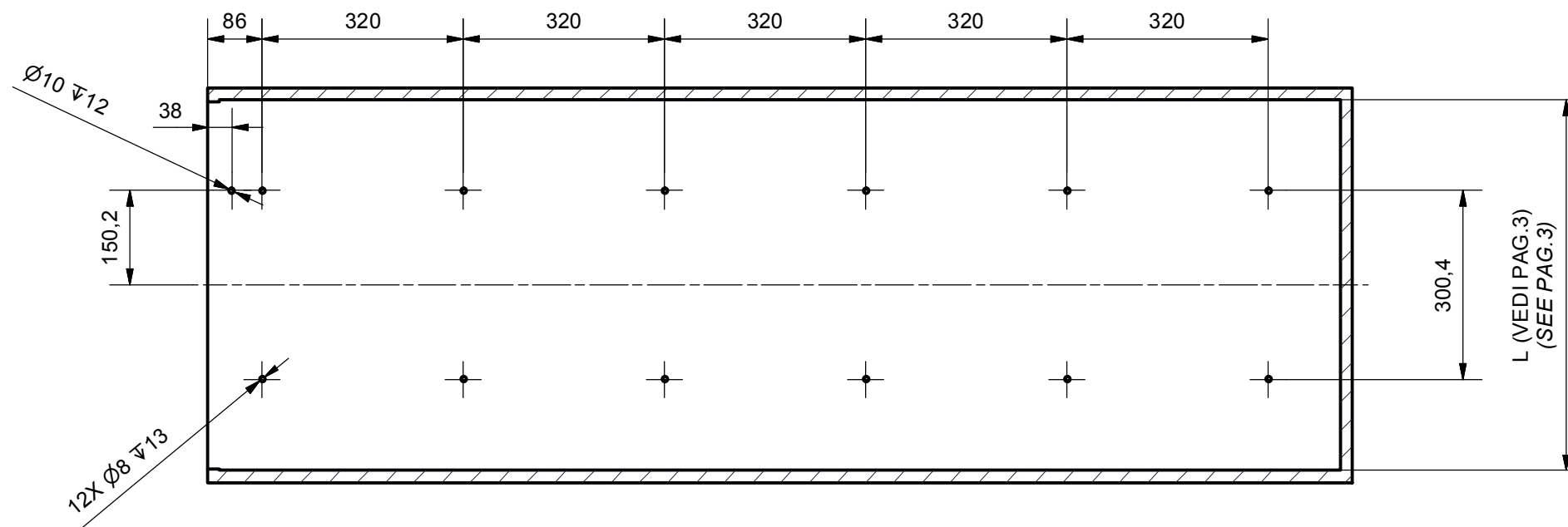
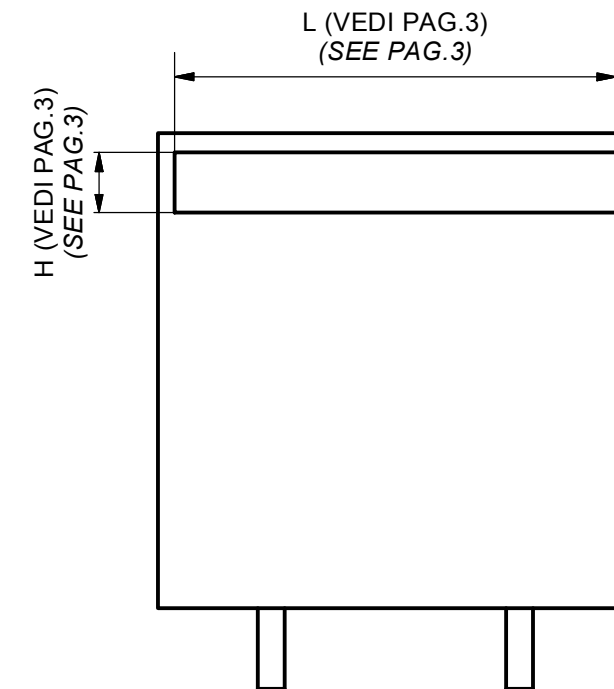
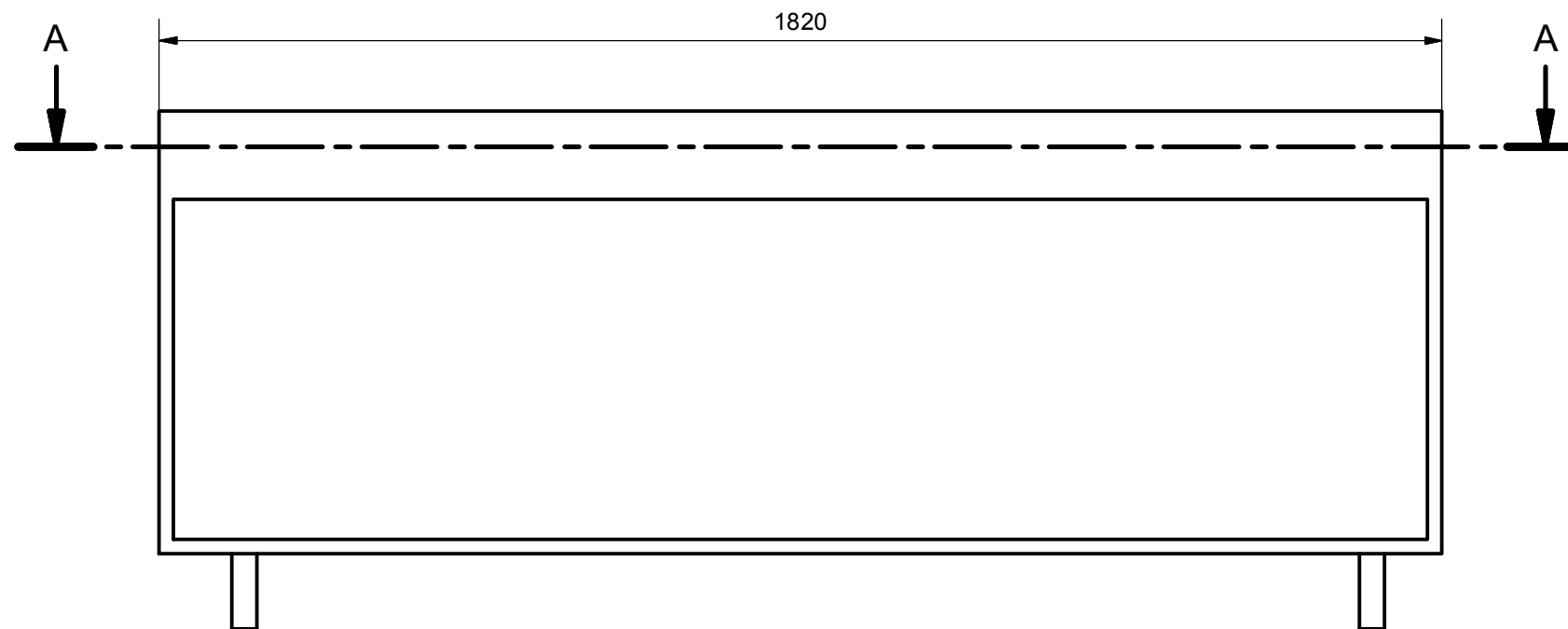

ACCESSORIES

C. Bussola M6 12x8 mm - Bush M6 12x8 mm (x12)

DIMENSIONI PIANO PLANE DIMENSIONS

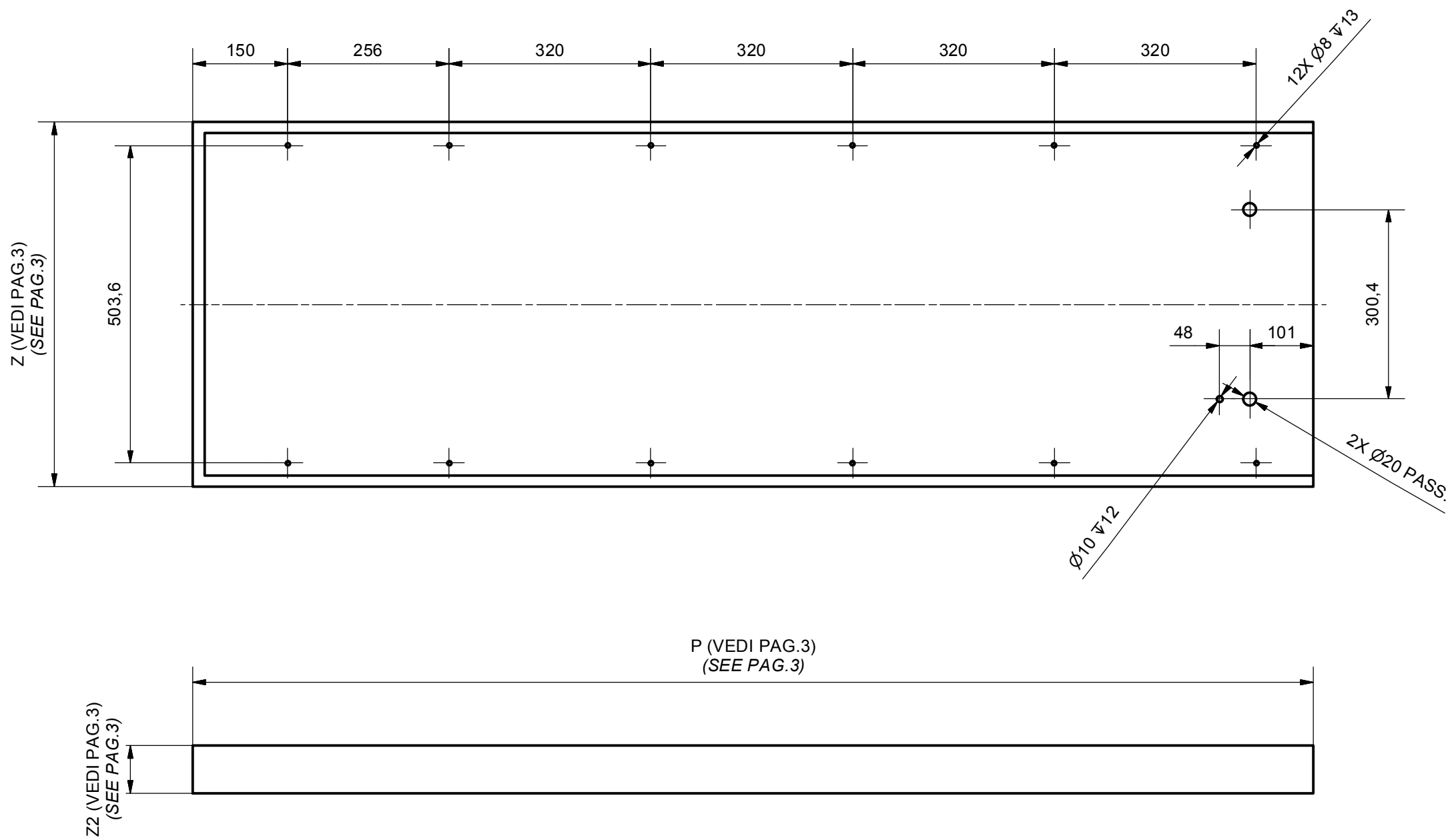

ACCESSORIES

C. Bussola M6 12x8 mm - *Bush M6 12x8 mm (x12)*

MONTAGGIO DEL MECCANISMO SUL MOBILE

MOUNTING OF THE MECHANISM ON THE CABINET

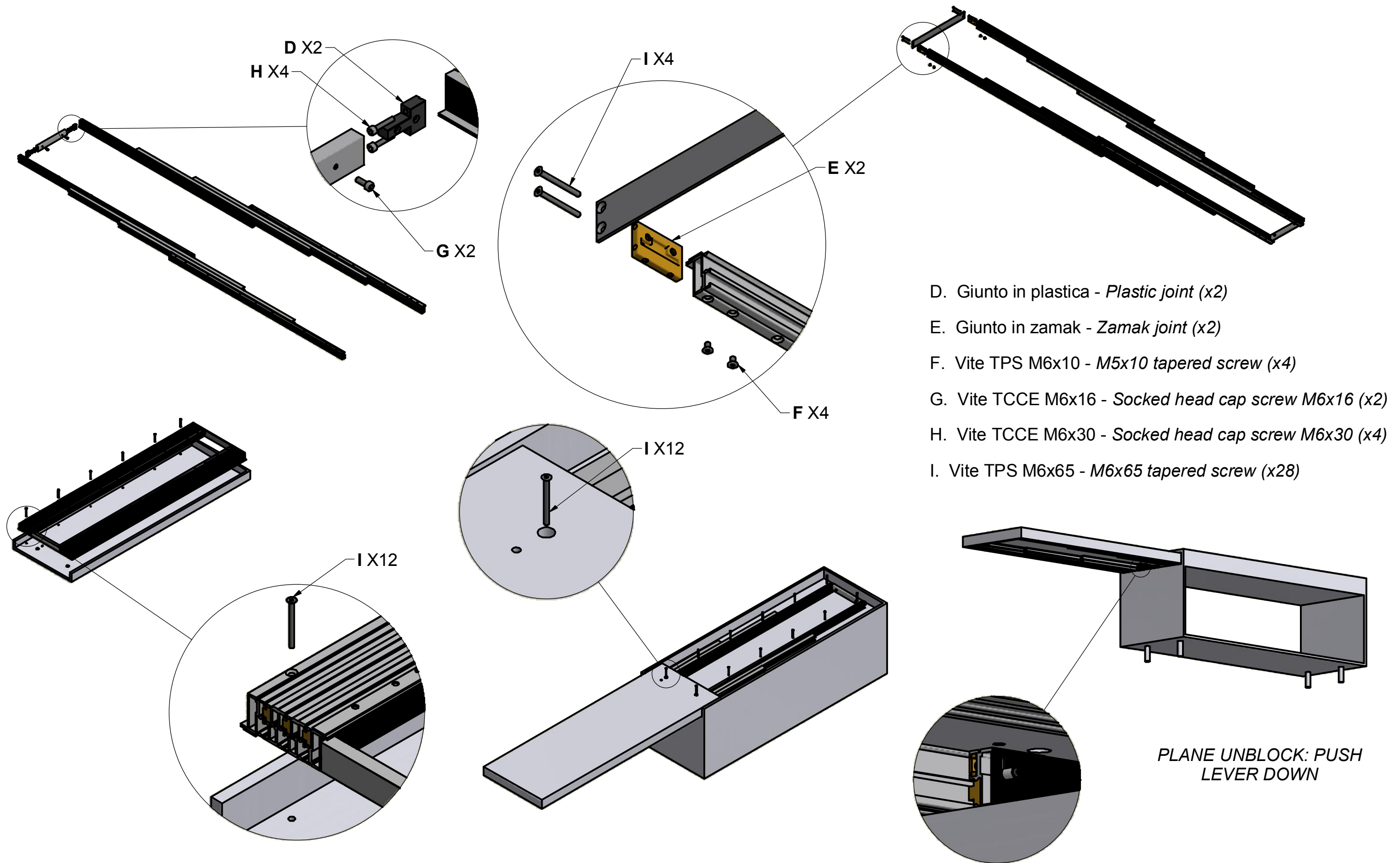

- D. Giunto in plastica - *Plastic joint (x2)*
- E. Giunto in zamak - *Zamak joint (x2)*
- F. Vite TPS M6x10 - *M5x10 tapered screw (x4)*
- G. Vite TCCE M6x16 - *Socked head cap screw M6x16 (x2)*
- H. Vite TCCE M6x30 - *Socked head cap screw M6x30 (x4)*
- I. Vite TPS M6x65 - *M6x65 tapered screw (x28)*